

CNC TURNING LATHE

VT-15L VT-17L VT-18L

HIGH PRECISION

- ▶ 6 or 8-inch chuck
- ▶ Live VDI-30 turret
- ▶ Rigid box ways

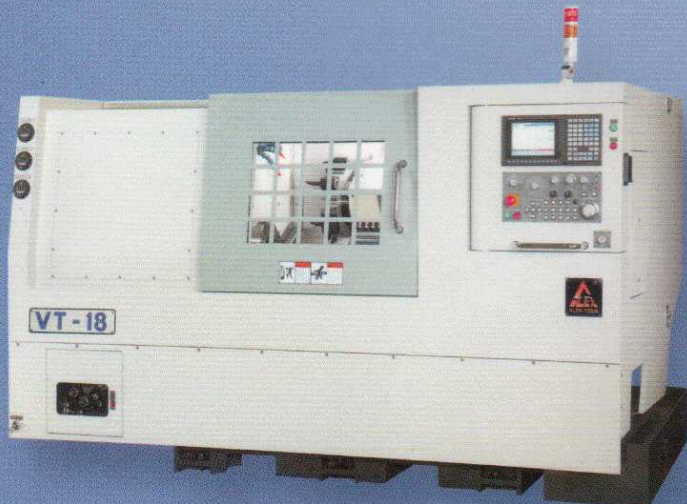

www.alex-tech.com

VIPER



*Perform
Hard Turning
On A Small
Footprint*

VT-SERIES

15L

17L

18L

High Precision

Turning Centers For Micro-Finishing and Hard-Turning

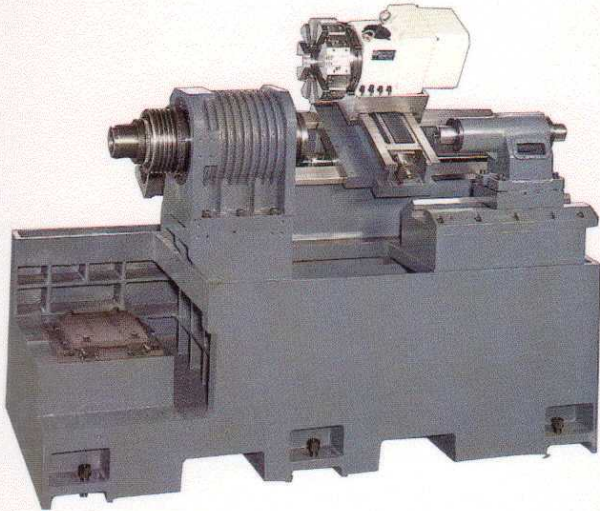

VT-15L / VT-17L

Z-Axis ways are box-type design and the X-Axis ways feature a box-type layout.

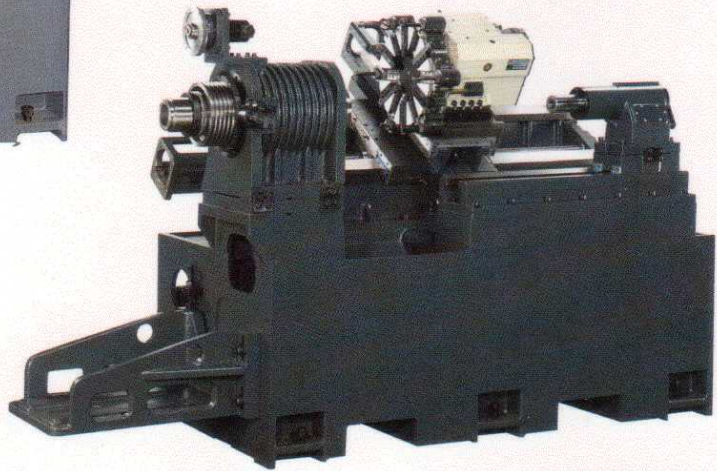

VT-18L

SOLID CONSTRUCTION

Rigid, one-piece Meehanite cast-iron-bed. Viper turning center construction provides the ultimate in machine tool accuracy and reliability.

A 30° slant bed design for our **VT-15L**, **VT-17L** and **VT-18L** gives Viper its exceptional cutting stability facilitating optimal chip removal. Cutting reaction forces are minimized resulting in a high degree of precision. Both X and Y axes on Viper turning centers are supported by oversized hardened and ground box type ways which facilitates exceptionally fast

cutting rates of 787 ipm (20 M/min.) on the X-Axis and 787 ipm (20 M/min.) on the Z-Axis.

PERFORMANCE FEATURES

- 6000 rpm for Micro-Finishing
- High Speed Servo Turret*
- 20 hp Spindle Motor*
- VDI-30 Live Turret*

(*) Optional accessory.

TORQUE CHARTS

VT-15/17 Torque Chart

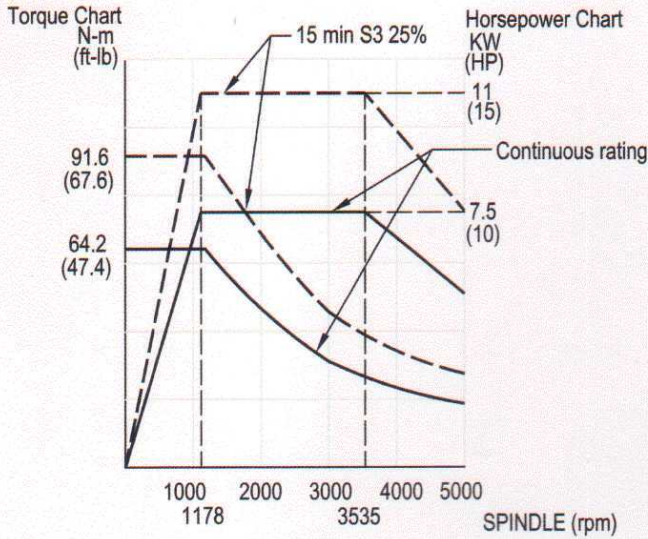

VT-15/17 Torque Chart (Option)

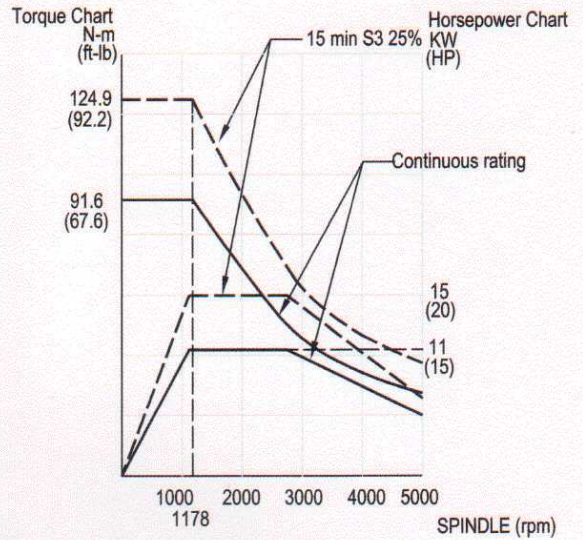

VT-18 Torque Chart

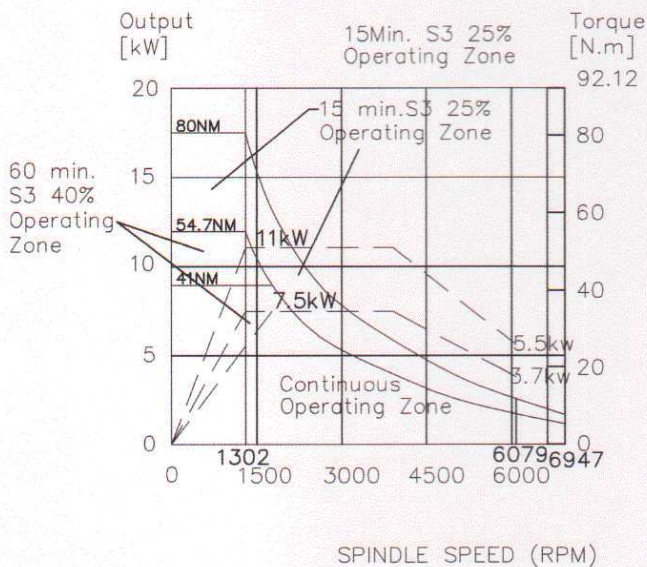

VT-18 Torque Chart (Option)

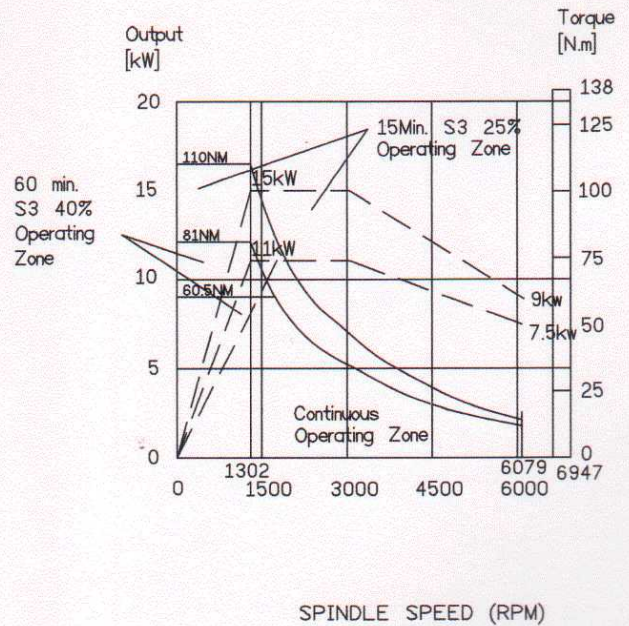

TURRET TOOLING

Static Block Tool

O.D. and face work

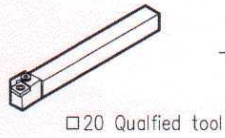

Direct mounting on turret

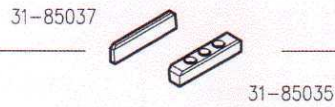

Face and I.D. work

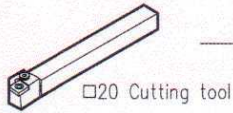

Tool holder for face work

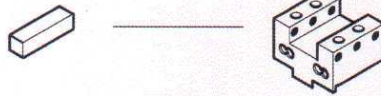

I.D. Cutting



Boring bar holder (U-Drill)

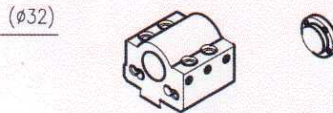

Boring bar holder

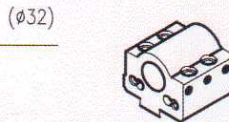

Boring bar sleeve

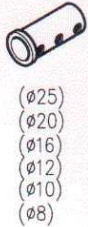
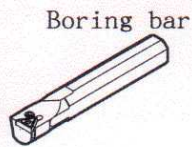

Boring bar sleeve

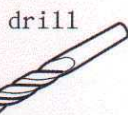
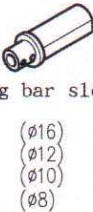

Drill socket

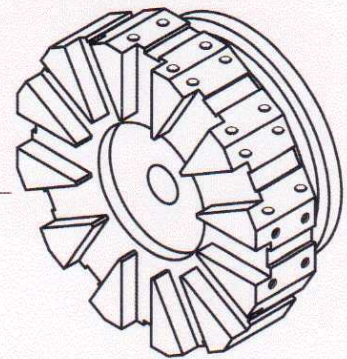

Turret head

Units = mm

TURRET INTERFERENCE DRAWING

VT-15L

Static Block Tool

20mm 12T HYDRAULIC TURRET

Duplomatic = 320 mm
Lio Shing = 320 mm
Sauter = 316 mm

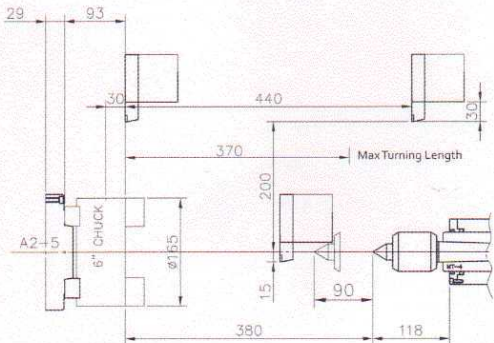
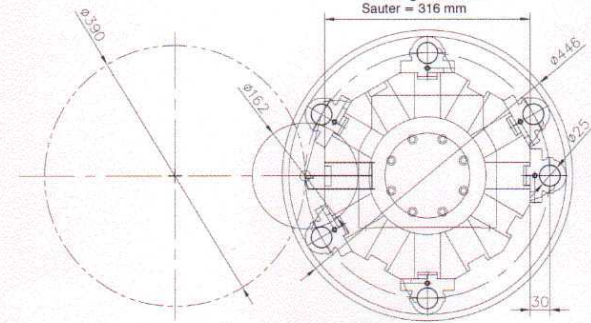

ISO A2-5

VT-15L

Live VDI 30

SAUTER
VDI30 PCD=300
VDI 30
COUPLING DIN5480

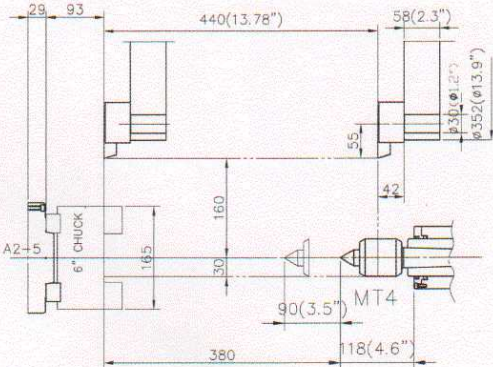
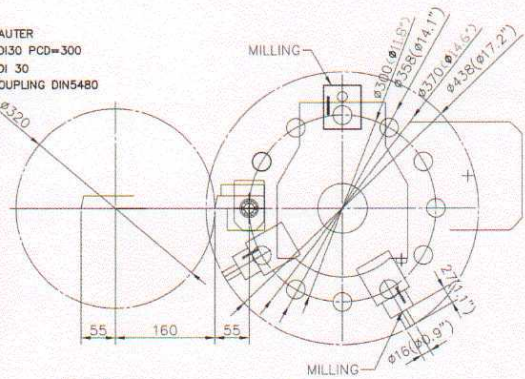

ISO A2-5

VT-17L

Static Block Tool

20mm 12T HYDRAULIC TURRET

Duplomatic = 320 mm
Lio Shing = 320 mm
Sauter = 316 mm

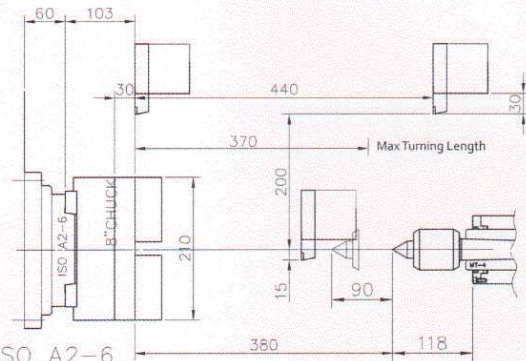
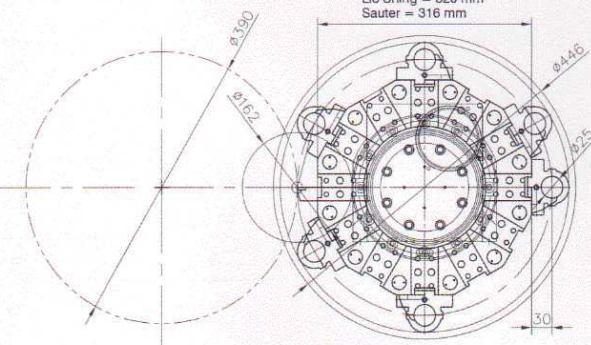

ISO A2-6

VT-17L

Live VDI 30

SAUTER
VDI30 PCD=300
VDI 30
COUPLING DIN5480

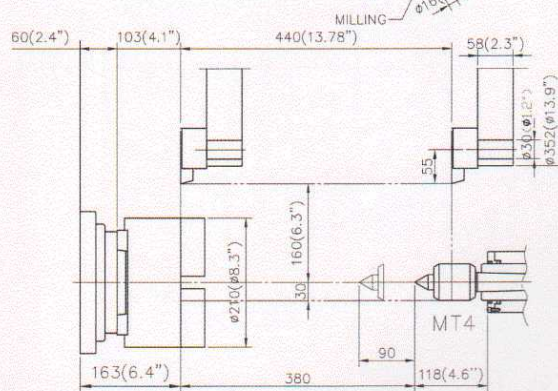
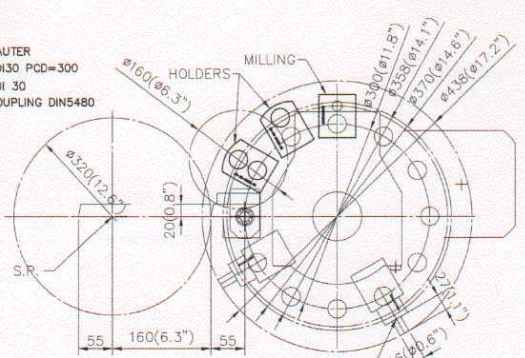

ISO A2-6

TURRET INTERFERENCE DRAWING

VT-18L

Static Block Tool

HYDRAULIC TURRET
12T

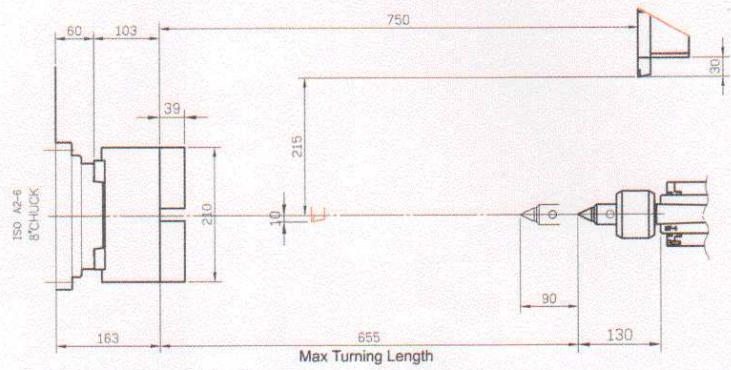
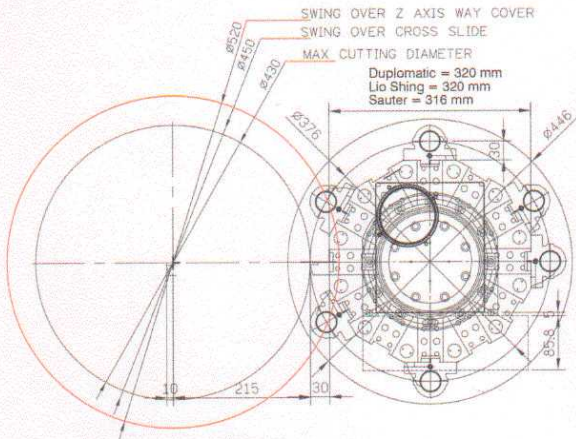

VT-18L

Live VDI 30

LIVE TURRET AXIAL
VDI30 PCD=300

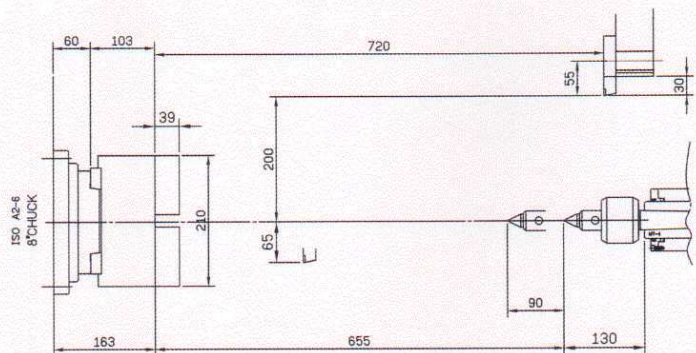
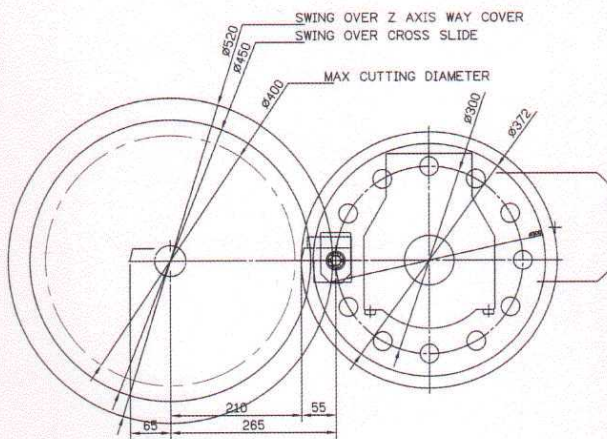

MACHINE DIMENSIONS

VT-15L • VT-17L CNC Turning Lathe

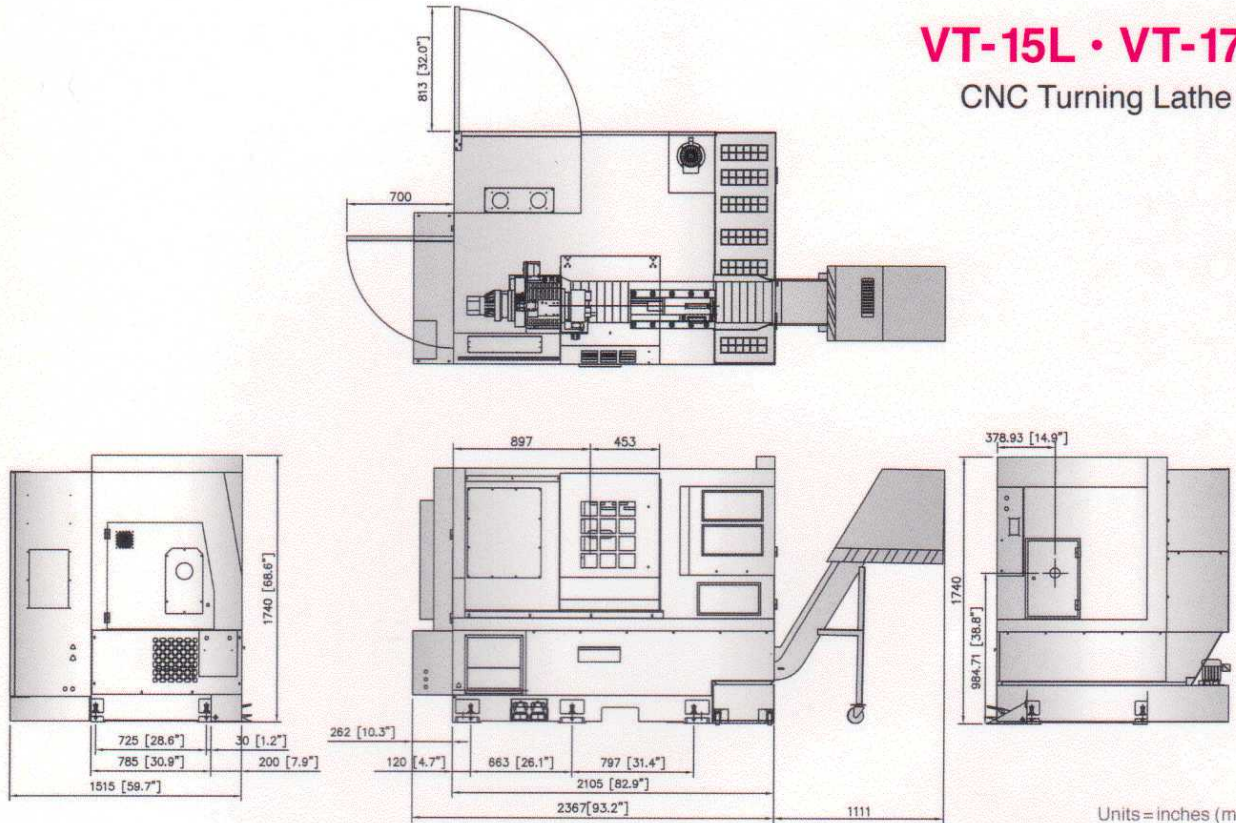

Units = inches (mm)

VT-18L

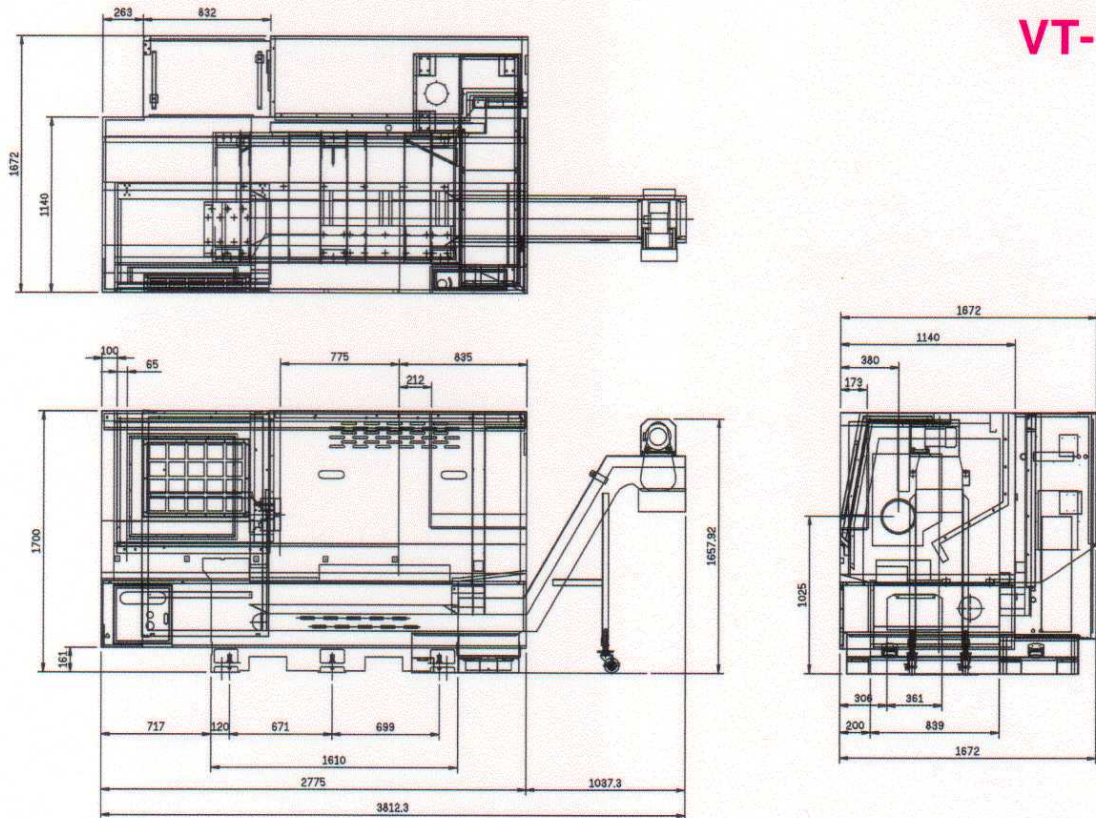

Machine Specifications

ITEM	UNIT	VT-15L	VT-17L	VT-18L
CAPACITY				
Swing over Z way cover	in (mm)	18.9 (480)	18.9 (480)	20.4 (520)
Max. turning diameter	in (mm)	15.3 (390)	15.3 (390)	16.9 (430)
Swing over cross slide	in (mm)	11 (280)	11 (280)	17.7 (450)
Distance between centers	in (mm)	14.6 (370)	14.6 (370)	25.6 (650)
Max. turning length	in (mm)	14.6 (370)	14.6 (370)	25.6 (650)
Slideway slant angle	degree	30	30	30
TRAVEL				
X-axis travel	in (mm)	7.87+0.59(200+15)	7.87+0.59(200+15)	8.85+0.39 (225+10)
Z-axis travel	in (mm)	18.5 (470)	18.5 (470)	29.5 (750)
SPINDLE				
Type of spindle nose	ISO	A2-5	A2-6	A2-6
Chuck diameter	in (mm)	6 (152)	8 (204)	8 (204)
Main spindle bearing inner diameter	in (mm)	3.5 (90)	4.3 (110)	4.3 (110)
Main spindle through hole diameter	in (mm)	2.0 (51)	2.4 (61)	2.4 (61)
Main spindle through bar capacity	in (mm)	1.7 (42)	2.0 (51)	2.0 (51)
Main spindle drive motor	hp (kW)	15 (11)	15 (11)	15 (11)
Main spindle speed range	rpm	6000	5000	5000
TURRET				
Turret type (Tool number)	—	Static Block Tool (12)/(10)*OPT Live VDI-30(12)		
Turret indexing time	second	0.8 = Hydraulic Driven / 0.15 = Servo Driven		
Live tool speed	rpm	6000	6000	5000
Live tool power (30 min.)	hp(kW)	5.0 (3.5)	5.0 (3.5)	5.0 (3.5)
FEEDRATE				
Rapid traverse rate X-axis	ipm (M/min.)	787 (20)	787 (20)	787 (20)
Rapid traverse rate Z-axis	ipm (M/min.)	787 (20)	787 (20)	787 (20)
Ballscrew diameter of X-axis	in (mm)	1.1 (28)	1.1 (28)	1.1 (28)
Ballscrew diameter of Z-axis	in (mm)	1.26 (32)	1.26 (32)	1.26 (32)
TAILSTOCK				
Tailstock travel	in (mm)	11.8 (300)	11.8 (300)	25.7 (655)
Tailstock quill diameter	in (mm)	2.4 (60)	2.4 (60)	2.4 (60)
Tailstock quill diameter travel	in (mm)	3.14 (80)	3.14 (80)	3.54 (90)
Taper hole of tailstock quill	—	MT-4	MT-4	MT-4
OTHER				
Power requirements	V (kVA)	208 (20) 3 Phase	208 (20) 3 Phase	208 (20) 3 Phase
Coolant pump motor	hp(kW)	0.75 (0.56)	0.75 (0.56)	0.75 (0.56)
Coolant tank capacity	gal (L)	54 (205)	54 (205)	66 (250)
Floor space	in (mm)	100 x 79 (2550 x 2010)	100 x 79 (2550 x 2010)	109 x 65 (2775 x 1672)
Machine weight	lbs(kg)	8140 (3700)	8250 (3750)	8366 (3795)

Design and specifications are subject to change without prior notice.

* Optional accessory | ** Factory order only

Standard Features

- Auto Lubrication System
- Block for Base
- Cooling System and Chip Tray
- Coolant Tank Guard
- Chip Conveyor
- Fluid Bearing Way System
- Hard Jaw (1 Set)
- Heat Exchange for Control System
- Hydraulic Adjustment System
- Lubrication Monitoring System
- Soft Jaw (1 Set)
- Tool box with Hand Tool
- Work Lamp



伍將機械工業股份有限公司
ALEX-TECH MACHINERY INDUSTRIAL CO., LTD.
 No. 5, Chun An Rd., Shengang District, Taichung City 429, Taiwan
 Tel:886-4-25626039 Fax:886-4-25626040
<http://www.alex-tech.com> E-mail:alextech@ms24.hinet.net

Optional Accessories

- Air chuck
- Automatic gantry loading and unloading system
- Bar feeder interface (Factory order only)
- Collect chuck (16C)
- Heavy parts loader
- High pressure coolant pump and large capacity tank
- High pressure coolant through turret 300 psi (4 gpm)
- High pressure coolant through turret 1000 psi (8 gpm)
- Parts catcher (2.5" x 6")
- VDI-30 live turret: 12-station turret
- 20 hp spindle motor (for non-live turret)
- Self-centering steady rest SMW autoblok
- Tool presetter
- Torque limiter clutch



CNC MAKINA SAN. ve TIC. LTD. ŞTİ.

Büsan Özel Organize Sanayi Sitesi: Fevzi Çakmak Mah. 2. Sk. No: 38
 : 0.332 - 345 18 38 Fax: 0.332 - 345 14 34 - 345 18 98 Karatay / KONYA
 Merkez
 Santral Gsm : 0.533 - 668 06 31
 e-mail : dms@dmscnc.com
 Ankara Şube : İvedik Organize San. Blg. Öz Anadolu Yapı Koop. 681 Sk. No: 23
 Tel : 0.312 - 394 41 00 Fax: 0.312 - 394 41 01 Yenimahalle / ANKARA
 Santral Gsm : 0.533 - 603 62 41
 Bursa Şube : Beşevler Küçük Sanayi Sitesi 26. Blok No: 37 BURSA
 Tel : 0.224 - 443 44 34 Fax: 0.224 - 441 71 07

MIGHTY USA, INC.
 19706 S. Normandie Ave.
 Torrance, CA 90502
 Tel. 310.516.7478
 Fax. 310.516.0368
 E-mail. sales@mightyusa.com

Catalog_VT-15/17/18-2014.09.v4