

HARTFORD

Hartford has sold over 44,000 machines globally, resulting in over 36,000 satisfied customers and a wealth of feedback that has added to our arsenal of experience and fine craftsmanship. In accordance with our insistence on providing only the highest quality of machining centers, every possible resource is utilized to constantly upgrade our technological levels in manufacturing and other applications.



Hartford
The machining center company

SMALL MACHINING CENTER

SMC-5

COMPACT MACHINING CENTER



- 50 M/min. rapid traverse rate
- Acceleration X / Y / Z: 1.4 / 1.4 / 1.2G
- Footprint is 23% less than #40M/C
- Overall machining efficiency is 40% higher than #40M/C

Hartford

The machining center company

SHE HONG INDUSTRIAL CO., LTD.
HEADQUARTERS

No. 6, 6th Rd., Industrial Park, Taichung, Taiwan, R.O.C.

Te l : 886-4-23592747

Fax: 886-4-23581793

<http://www.hartford.com.tw>

EU TECHNICAL CENTER

Prague, Czech Republic

DISTRIBUTION CENTER

Le Havre, France Istanbul, Turkey Bangkok, Thailand
Caxias Do Sul, Brazil Buenos Aires, Argentina

SALES & SERVICE CENTER

Korea - Seoul, Busan, Daegu
China - Tianjin, Shanghai, Foshan, Huangyan, Shenyang
Taiwan - Taipei, Hsinshu, Taichung, Kaohsiung

CAT. NO. SMC-100412E03

VERSATILE AS A TAPPING CENTER,
CUTS LIKE A MACHINING CENTER

HARTFORD SMC-5

An Efficient Compact Machining Center
Specially Designed for **3C INDUSTRIES**.

Now, a compact machining center from Hartford is available to help you improve light duty and high speed machining quality, as well as maximize your working efficiency. You get unmatched performance in drilling and tapping operations.



Applications

[Hand Tools]



[Auto Parts]



[Smart Phones]



[Tablets]



[Hard Disks]

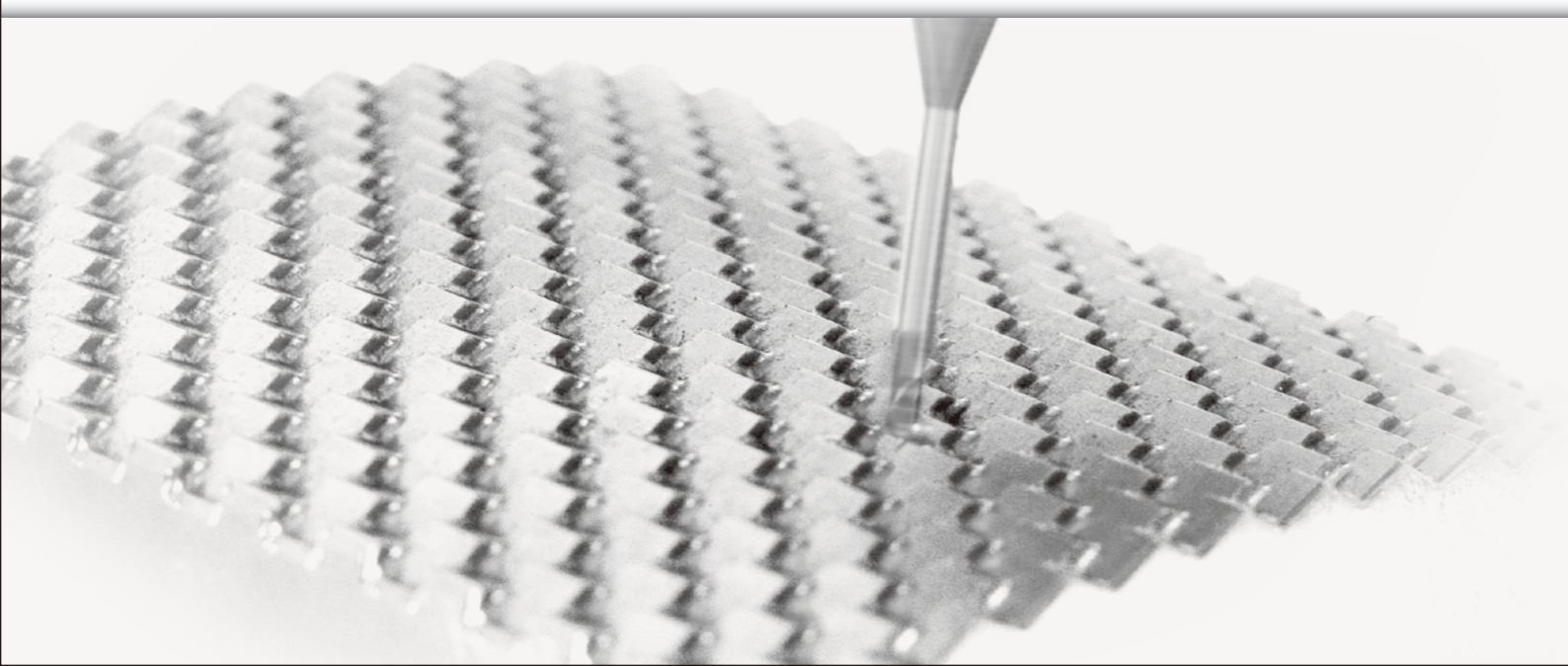

THE ULTIMATE STRUCTURE

Designed, Engineered And Manufactured To Uncompromising Quality Standards, The Hartford **SMC-5 MACHINING CENTER** Features Unmatched Rigidity And Stability Year After Year.

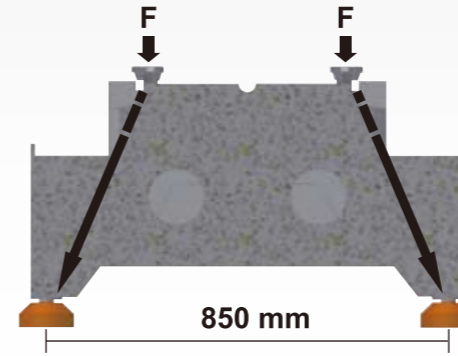

FEATURES OF MACHINE BASE

Reference:

The machine adopts Meehanite cast iron, featuring structural stable and reliable, combined with a high rigidity, large base span column, which offers absolute stability and accuracy.

The low gravity center strengthens the structural rigidity of the machine base, and greatly reduces vibration, during cutting.

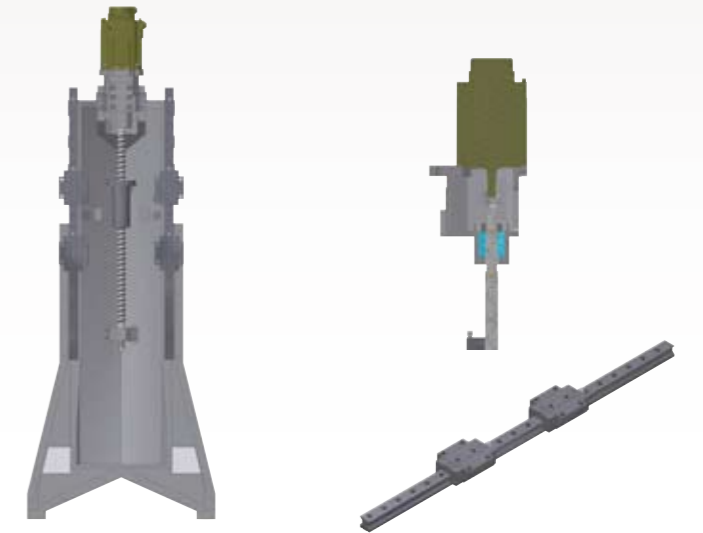

FEATURES OF MACHINE COLUMN

Reference:

3 axes are designed with direct drive structure, together with high rigidity coupling which increases servo response and reduces backlash problem, displaying perfect accuracy and reliability during high speed movement. To increase Z axis transmission rigidity, the Z axis employs 3 bearings with roller type linear guideways, It is not only suitable for drilling and tapping, but also for engraving and milling operations.

MASSIVE BASE & COLUMN

The heavily constructed base and column with scientific rib reinforcement dramatically upgrade structural strength and rigidity.

NO COUNTER BALANCE

The over-sized Z axis ball screw powers the head stock moving up and down rapidly and smoothly, displaying the speed of tapping center, and rigidity of machining center.

50 M/MIN. RAPID TRAVERSE RATE

The rapid traverse rates on the X, Y and Z-axes reach 50 M/min., which greatly reduces non-cutting time, while increasing productivity. (Mitsubishi)

HIGH ACCELERATION

The acceleration of X/Y/Z axes are 1.4/1.4/1.2G respectively. This extraordinary performance is guaranteed to satisfy your high productivity demands.

HIGH QUALITY CAST IRON

All structural parts are manufactured from high quality Meehanite cast iron, and stress relieved for outstanding material stability.

LINEAR WAYS ON 3 AXES

The linear ways on the X, Y and Z-axes are high grade and exhibit a greater span design to achieve maximum stability during machining.

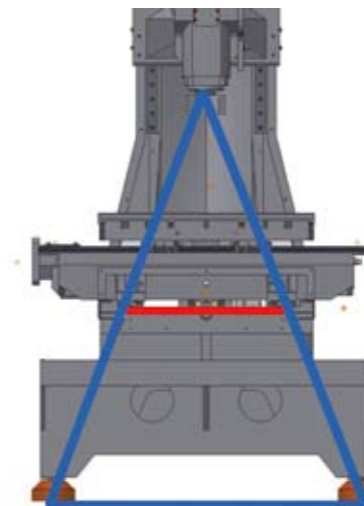

LARGE SPAN BETWEEN SLIDEWAYS

- The triangular golden ratio design features extraordinary balance. The center of gravity remains in a low position, allowing high speed movement with high accuracy.
- The transmission ball screws are deployed on the same plane with linear guideways, which maximize accuracy during high speed machining.

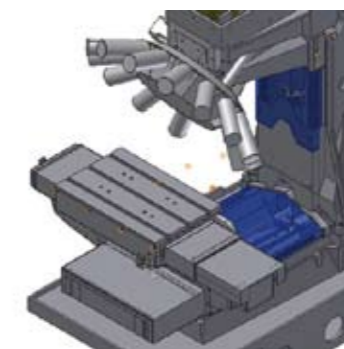

ONE-PIECE SLIDEWAY METAL COVERS ON Y/Z AXES

- Prevents chip ingestion to ball screw and linear guideways.
- High speed, low noise and vibration-free.



RIGID HEADSTOCK

The headstock is a rugged construction, providing a solid support for the spindle.

14/21 TOOL TURRET

- ATC TYPE (Servo)

- The turret-type magazine provides a choice of 14 and 21 tools.
- The armless ATC features fast tool change in 1.6 seconds (14 tool turret) and 1.8 seconds (21 tool turret).

SPINDLE

Direct Drive Spindle

**12,000 RPM (STANDARD),
15,000 / 24,000 rpm (Optional) (Mitsubishi)**

- The spindle is directly driven by a silent motor, without backlash or vibration problems, which usually occur on belt or gear-driven spindles.
- The direct drive spindle design provides higher motor efficiency. Spindle speed is directly controlled by the motor for superior tapping quality.
- Extra low inertia spindle motor is also available.

Acceleration X/Y/Z: 1.4/1.4/1.2G

Low Inertia, High Speed Acceleration / Deceleration Spindle Motor

A new spindle motor is added to the lineup for faster drilling and tapping. Its low inertia can shorten acceleration/deceleration time and assure higher productivity. In addition, further downsizing and energy savings are possible. This motor is driven by multi-hybrid drive.

Increase Machining Efficiency

It dramatically upgrades rapid traverse rate and acceleration / deceleration, reducing non-cutting time, while increasing machining efficiency.

- Rapid traverse rate: 50m/min.
- X-axis acceleration: 1.4G
- Y-axis acceleration: 1.4G
- Z-axis acceleration: 1.2G

Shortened spindle orientation time.
Increased spindle acceleration.
Shortened tool change time.

- Tool change time: 1.4 sec. (T to T)
- Acceleration time: 1.5 sec. (S0 → S12000)
- Deceleration time: 2.2 sec. (S12000 → S0)
- Spindle orientation: 3.9S (S12000 → M19)
- Test conditions: BT40 spindle



REAL SPEED NOT EXPRESSED BY C-C

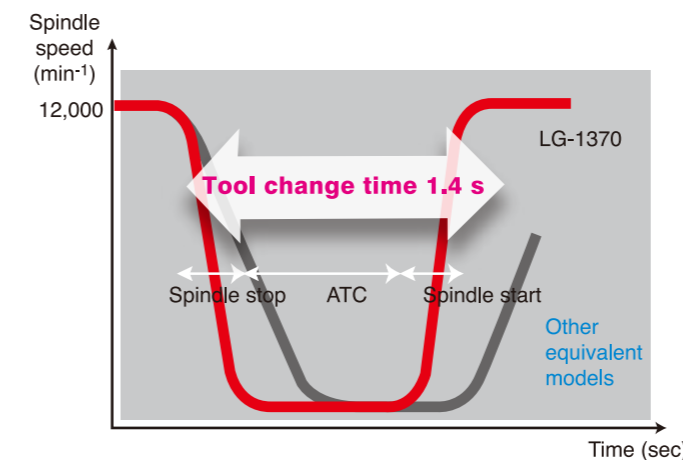

**HIGH / LOW SPINDLE SPEED
0 ~ 8000 ~ 0 r.p.m**

RPM	SJ-V5.5-01ZT(standard)
0~8000	1.8 second
8000~0	2.2 second

RPM	SJ-VL11-27ZT(Low inertia)
0~8000	1.1 second
8000~0	1.5 second



HARTROL

COUNTDOWN OF MACHINING TIME (OPTIONAL)

Purpose:
Machine down time may result in wasted resources. If the time remaining for programs to finish is known, an operator may prepare workpiece loading and unloading in advance. This means it is not necessary to wait until the machine stops—keeping down time to a minimum.

Application:
Large LED display can be placed on the machine for board management.

Applicable Controllers:
Mitsubishi and Fanuc Controllers

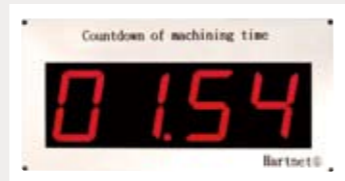

10 SETS OF MACHINING PARAMETERS PACKAGE

Purpose:
To expand machining parameters package from the original 3 sets to 10 sets. This permits the user to specify parameters package in programs to meet specific machining requirements (such as speed, accuracy, fineness and load), without the need to change parameters on the parameter display.

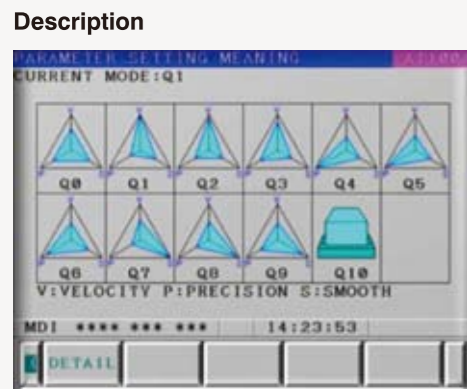

G100Q1	Speed priority (speed grade 100%)
G100Q2	Speed priority (speed grade 90%)
G100Q3	Speed priority (speed grade 80%)
G100Q4	Accuracy priority (accuracy grade 100%)
G100Q5	Accuracy priority (accuracy grade 90%)
G100Q6	Accuracy priority (accuracy grade 80%)
G100Q7	Fineness priority (fineness grade 100%)
G100Q8	Fineness priority (fineness grade 90%)
G100Q9	Fineness priority (fineness grade 80%)
G100Q10	Load priority

SELF SETTING PECK DRILLING CYCLE G183 (AI100 ONLY)

Item	Drilling conditions	Before improvement (G83)	After improvement (G183)	Efficiency increase
Fanuc G183 Special Peck Drilling Cycle Test	Total holes: 5	142.592 (sec)	84.869 (sec)	40.5%
	Total depth of drilling: 9 mm			
	Q value: 0.6 mm			
	Feed rate: 150 mm/min.	115.808 (sec)	57.728 (sec)	50.2%
	Total holes: 3			
	Total depth of drilling: 7 mm			
Q value: 0.3 mm				
Feed rate: 150 mm/min.				

COOLANT SHOWER

LOWER TEMPERATURE, HIGHER ACCURACY

- Effectively brings the cutting chips to the chip conveyor and chip cart.
- Stabilizes the temperature of work piece and cutting tool.
- Standard top lid ensures comfortable working environment.

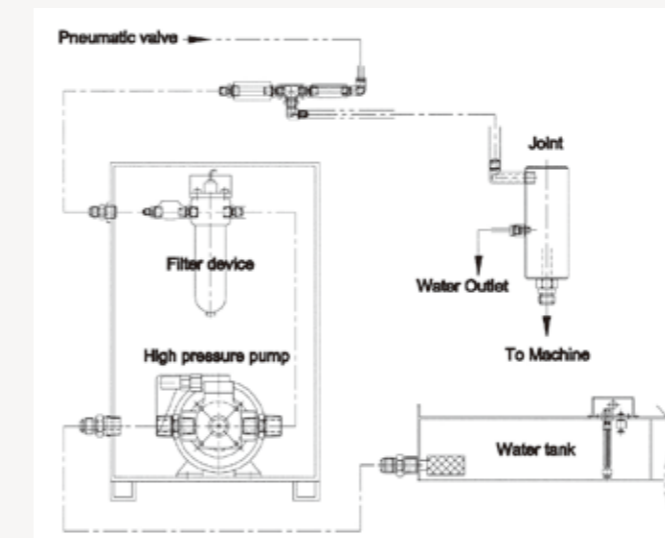
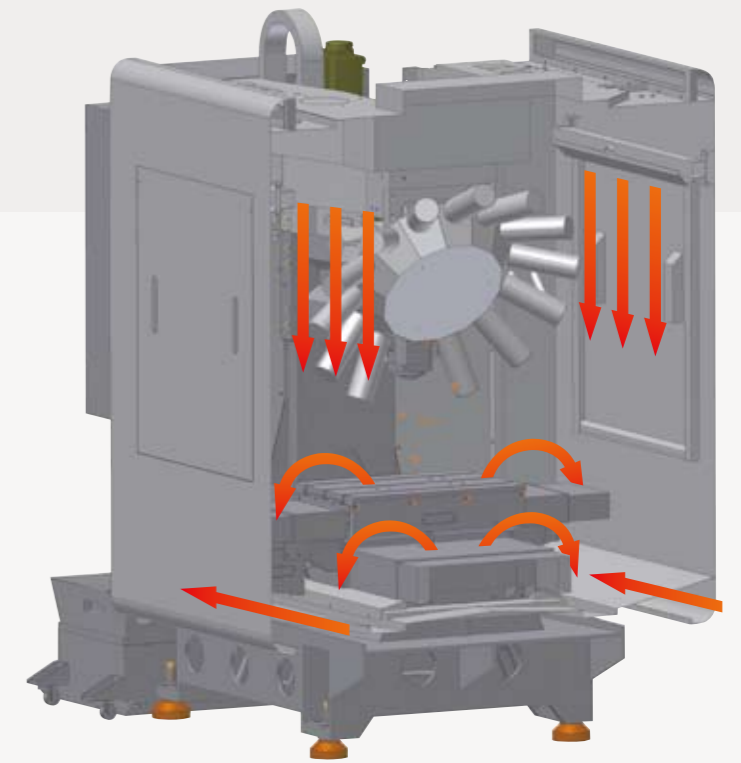

20/25/70 BAR COOLANT THROUGH SPINDLE (OPTIONAL)

The 20 bar coolant through spindle system integrates a filter and high pressure coolant pump in a compact structure. It delivers high pressure coolant to the cutting edge to improve tool life and permits higher speeds, deep hole drilling and pocket milling.

- The coolant pressure in the max. output at the coolant pump outlet.

Machine Dimensions

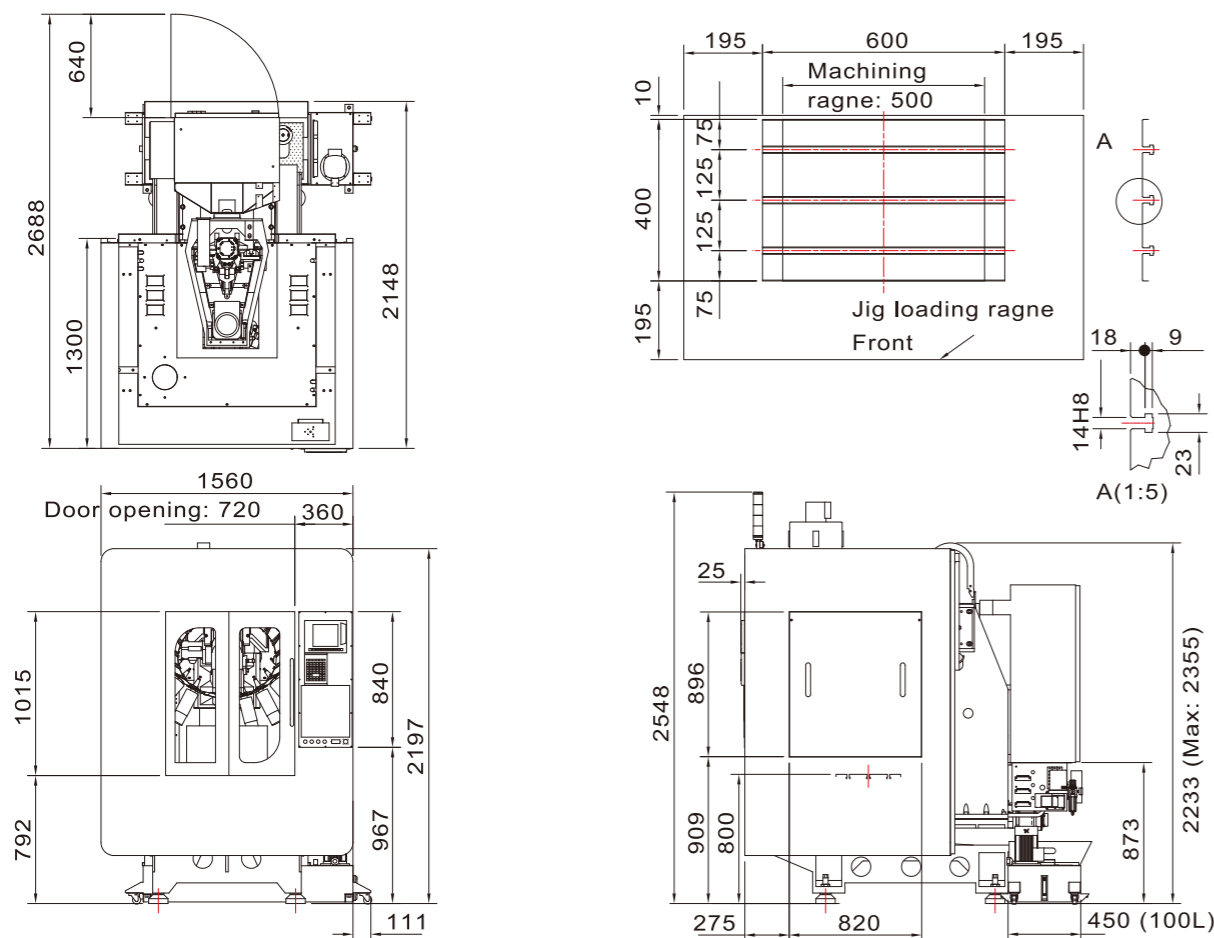

COMPACT FOOTPRINT

- The rear chip-disposal design increases chip evacuation efficiency and saves floor space occupied by the machine.
- For an entire production, for instance, with 5 machines in a row, the needed space is 23% less than the machine with side chip-disposal design.

Total Space:

FOOTPRINT IS 23% LESS THAN #40M/C

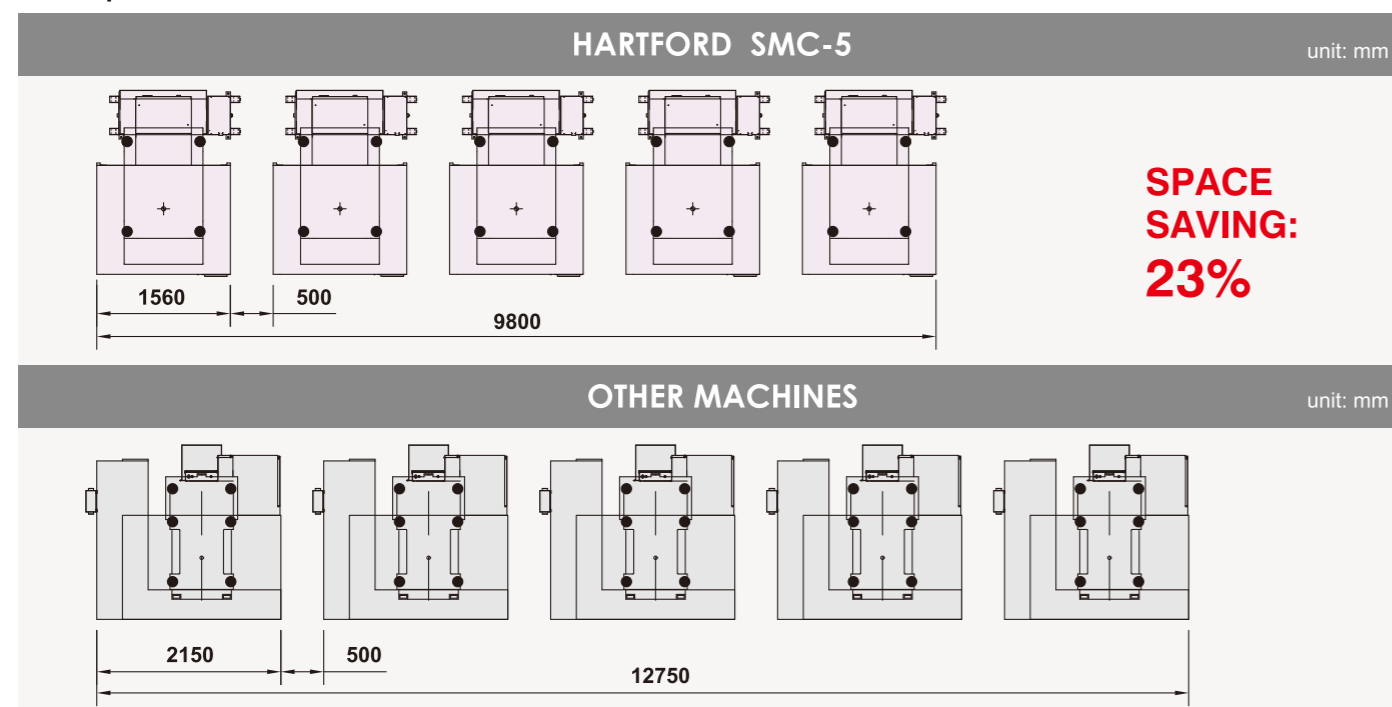

Machine Specifications

MODEL	UNIT	SMC-5 (MITSUBISHI M70VB)	SMC-5 (Fanuc 0iMD)	SMC-5 (Syntec 10A)
TABLE				
Working surface	mm	600 x 400		
T-slot (size x number x pitch)		14 x 3 x 125		
Max table load	Kg	250		
TRAVEL				
Longitudinal Travel (X-axis)	mm	500		
Gross travel (Y-axis)	mm	400		
Vertical travel (Z-axis)	mm	300		
Distance from spindle end to table center	mm	180~480		
High column for 150 mm	mm	330~630		
High column for 300 mm	mm	480~780		
SPINDLE				
Spindle nose taper		ISO30		
Spindle speed (DDS)	r.p.m.	12000 (15000 / 24000 opt.)	10000	18000 (24000 opt.)
FEED				
Cutting feedrate	mm/min	20000		
Rapid traverse (X,Y,Z axes)	m/min	50 / 50 / 50	48 / 48 / 48	
Machining acceleration (X,Y,Z axes)	G	1.4 / 1.4 / 1.2	1.4 / 1.4 / 1.2	
ATC				
Tool storage capacity	PCS	14 / 21 (Turret Type)		
Max.tool weight	kg	3		
Max.tool size (diameter x length)	mm	Ø80 x 250		
Tool change (servo)	sec.	1.6 (14 Tools) / 1.8 (21 Tools)		
Tool shank		BT30		
Pull stud bolt		P30T-1		
MOTOR				
Spindle drive motor (30min)	kW/HP	2.2 / 3.7 (3.7 / 5.5 opt.) (Option with Low Inertial Motor)	2.2 / 3.7 (3.7 / 5.5 opt.)	
X · Y · Z axis drive motor	kW	1.5 / 1.5 / 1.5	1.2 / 1.8 / 1.8	1.5 / 1.5 / 2
OTHER				
Required air pressure	Kg/cm ²	6.5		
Electric power consumption	KVA	16		
Machine weight	kg	2100		
Floor space (Full Guarding)	mm	1565 x 2040 x 2548		

STANDARD ACCESSORIES

- Full-Enclosed Splash Guard
- Cooling System
- Air Blast Through Spindle
- Fluorescent Lamp
- Leveling Bolts And Blocks
- Tool Package
- Operation And Electric Manual Drawing Equipent
- Operation Finish Lamp
- Auto Power Off
- Turret-style 14 Tool Magazine
- Table Side Air Blast
- Spindle Air Curtain
- Coolant Flushing Device

OPTIONAL ACCESSORIES

- Turret-style 14 Tool Magazine for Servo
- Turret-style 21 Tool Magazine for Servo
- DDS Spindle speed 10000rpm for Fanuc
- DDS Spindle speed 15000rpm
- DDS Spindle speed 24000rpm
- Low Inertial Motor (Mitsubishi)
- Automatic door
- High column for 150mm
- High column for 300mm
- Fluorescent Lamp
- NC Rotary Table
- Spindle Oil Cooler
- Mist Coolant System
- Oil Mist Collector System
- X, Y, Z-Axis Ball Screw Enforce Pressure
- Squeegee Type Chip Conveyor
- Link Type Chip Conveyor
- Coolant Through Spindle
- 20BAR Coolant Through Spindle
- Coolant Gun
- Air Gun
- Remote Manual Pulse Generator
- Rs-232 Interface
- Convection Heat Exchanger In Control
- DNC Software
- Auto Tool Length Measurement
- Auto Work Piece Measurement
- Tool Breakage Detection System